

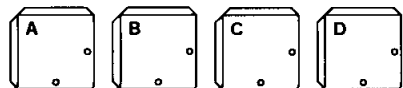

SICO CAM-LOCK PORTABLE FLOOR

Step 1



Steps 2, 3

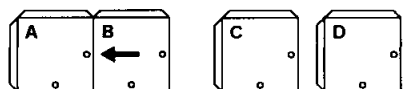

Steps 4, 5

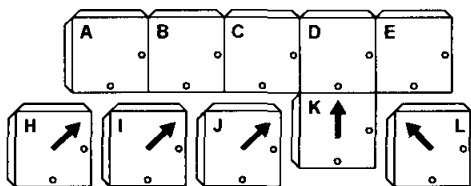

TO ASSEMBLE FLOOR PANELS

1. Place one row of panels (A,B,C,D...) on the floor, with their tongues pointing in the same direction.
2. push panel B into panel A so they are **tight** together and perfectly **aligned**. Use the supplied T-type hex wrench to firmly tighten the cam-lock that locks the panels together. Rotate approximately 180° clock-wise to lock the panels together.
3. In the same way, install the remaining panels in the first row. keep all panels carefully aligned and tight together.
4. Place the second row of panels (H,I,J,K...) close to the first. push panel K (near the center of the row already assembled) into the panel D and tighten the cam-lock. Panel K and D must be **tight** together and **aligned**.
5. Build the second row outward in both directions, then repeat for each additional row.
IMPORTANT: Four panels should always form a perfect cross.

TO ATTACH EDGE TRIM

Attach groove trim sections to the tongue floor panels. Lock together with the cam-lock located in the groove trim section. Attach tongue trim sections to the groove floor panels. Lock together with the cam-lock located in the groove floor panels.

Make certain clips in corners of the edge trim are inserted into slots of adjacent corners.

TO DISASSEMBLE THE FLOOR

Using supplied hex wrench, release all cam-locks by rotating counter-clockwise. To avoid damaging the cam locks or the aluminium edges, do not attempt to separate panels until cam-locks are released.

TO STORE PANELS

- Insert the edge trim strips vertically (square ends down) into the storage rack on the rear of the Sico Caddy. Secure the trim by sliding the trim-lock against the trim pieces.
- Starting at the rear of the caddy, place the panels on the Caddy one at a time with the tongue edge down.
- When all the panels have been placed on the caddy, secure them by sliding the panel-lock against the face of the front panel.
- Store the hex wrench in one of the holes to the rear of the panel-lock.

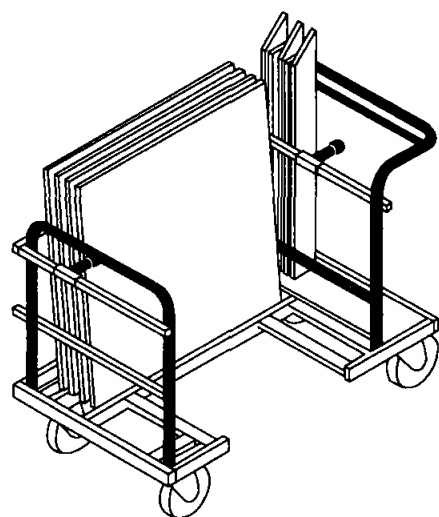

WARNING



Do not use floor:

- Unless panels are locked tightly together;
- If 1/18" or more gap shows between panels and/or edge trim;
- When wet;
- Without edge trim;
- If surface is uneven or has missing sections.

Failure to follow instructions could cause a fall and serious injury.

User assumes the full responsibility for installation and use of all dance floor components.

Inspect the assembled floor periodically. Remove damaged or loose components, and make any necessary repairs to return the floor to its original standards.

This product contains wood, glue and plastic which, if subjected to heat or flame, will burn - causing heat, fumes, and consumption of oxygen.

This could cause serious injury or death!

Periodic Maintenance - Wood Parquet Floor

LIGHT CLEANING. Dry-mop, sweep, or vacuum floor daily. Damp-mop floor as required with mineral spirits or one-step wax cleaner products such as Bruce Lite n' Brite, Max-Wax & Cleaner, or Dura Top Wax & Cleaner.

HEAVY CLEANING. Use mineral spirits or solvent-based (mineral spirits) wood cleaner such as Bruce Clean & Strip or Trewax Wood Cleaner. Always re-apply wax after using floor cleaning.

WAXING. One-step cleaner waxes (see 'Light Cleaning') are also recommended for waxing floor after heavy cleaning. **Paste wax is not recommended**, as wax build-up will increase required maintenance.

If desired, the floor may be polished with an electric buffer after drying.

NEVER use water or water-based cleaners or waxes on your SICO wood floor!
NEVER use alcohol, ammonia, kerosene, or turpentine on your SICO wood floor!
Check the set screws for dirt in the sockets. Check that the screws will tighten (not stripped).

Periodic Maintenance- Plastic Laminate Floor

Use a general household cleaner suitable for tile floors. No wax is necessary, but occasional buffing will bring out the shine in the floor.



Sico Europe Limited
The Link Park,
Lympe Industrial Estate,
Lympe, Kent CT21 4LR
Tel: +44 (0) 1303 234000
FREE PHONE: (UK only) 0800 085 8186
Fax: +44 (0) 1303 234001
e-mail: sales@sico-europe.com
www.sico-europe.com

04/04 Part No. 106901-GB



DATE: 26/05/04 M1 CLIENT: SICO EUROPE LTD CREATED BY: TL
WIT No: 8157 LABEL SIZE: 237mm x 317mm CUST. REF: 106901

COLOURS:

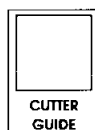
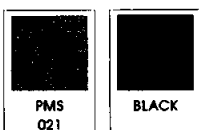

BASE MATERIAL: WHITE

PLEASE NOTE: THIS ARTWORK HAS BEEN CREATED ON OUR COMPUTER SYSTEM PLEASE CHECK CAREFULLY THE COLOURS SHOWN ABOVE ARE FOR USE AS A GUIDE ONLY AND DO NOT REPRESENT A TRUE COLOUR MATCH