

# SOCIALIZER® TABLE Operating Instructions

**READ INSTRUCTIONS  
BEFORE OPERATING**

**LEA LAS INSTRUCCIONES  
ANTES DE USAR**

## **TO MOVE      PARA MOVER**

Make sure the wheels are not locked before moving the table.  
**ALWAYS** push from the end of the table.

*Antes de mover la mesa asegúrese de que las ruedas no estén trabadas. SIEMPRE empuje tomándola por el borde.*

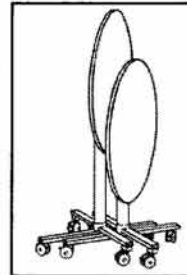
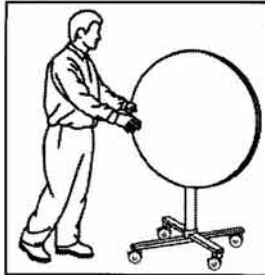

Nested tables in the storage position.

*Mesas encajadas en la posición de almacenamiento.*

## **TO FOLD TOP DOWN: PARA BAJAR LA TAPA:**

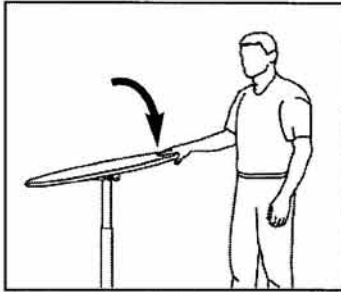

Grasp the table top and carefully rotate down until it is locked in place.

*Tome la tapa de la mesa y hágala girar hacia abajo hasta que encaje en su lugar.*

## **TO FOLD TOP UP: PARA SUBIR LA TAPA:**



**1** Grasp the table top and the handle under the table.

*Tome la tapa de la mesa y la palanca que está bajo la mesa.*

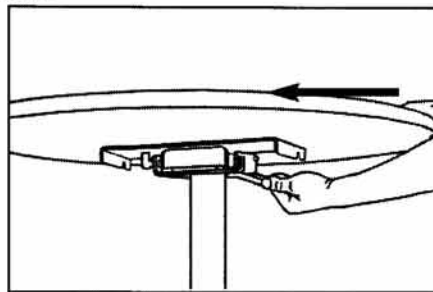

**2** Firmly hold the handle while pushing the table top away from you.

*Sujete la palanca a la vez que empuja la tapa alejándola de usted.*

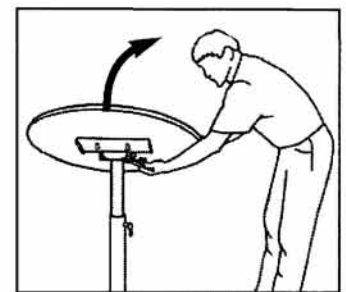

**3** Tilt the table top up to the storage position.

*Incline la tapa de la mesa hasta que quede en la posición de almacenamiento.*

## **TO LOWER TOP FRAME: For Dual Height Models PARA DISMINUIR LA ALTURA: En Modelos de dos Alturas**

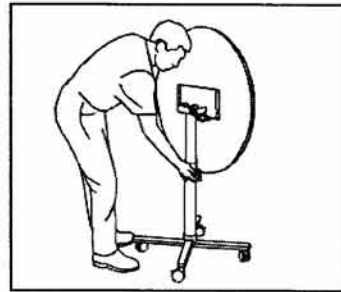

**1** Locate the column lock at the center of the column.

*Encuentre la traba de la columna en el centro de la columna.*

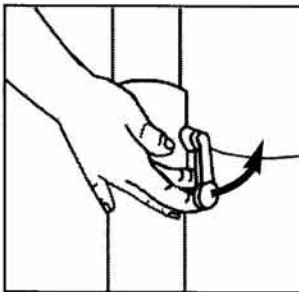

**2** Flip the lock handle up.

*Haga girar la palanca de trabado hacia arriba.*



**3** Push table top down to the desired height.

*Empuje la tapa de la mesa hacia abajo, a la altura deseada.*

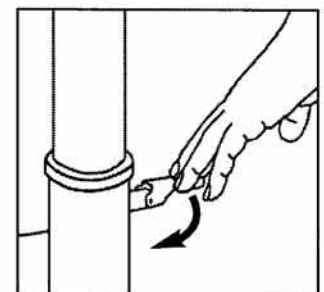

**4** Flip the lock handle down to activate the lock.

*Gire la palanca de trabado hacia abajo para fijar la traba.*

## **TO LOCK CASTERS: INMOVILIZACIÓN DE LAS RUEDAS:**

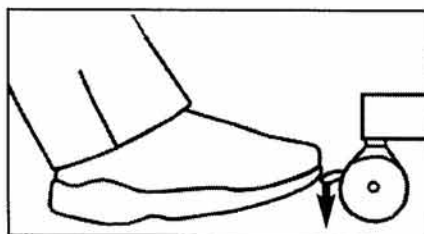

Step down on the tab at the front of the wheel.

*Pise la lengüeta en frente de las ruedas.*

**SICO** SICO AMERICA INC.  
1-800-424-0796  
WWW.SICO.COM  
PART NO. 117476 Rev. B REV. DATE 11/02



SICO AMERICA INCORPORATED  
 7525 Cahill Road  
 Minneapolis, MN 55439, USA  
 Customer Service: 1-800-424-0796  
 Website: [www.sicoinc.com](http://www.sicoinc.com)

# SOCIALIZER® TABLE Part List

**When Ordering Replacement Parts:**

All Parts - Indicate table Serial Number  
 (located under the top, near center of  
 table: it is a seven-digit number.)

- 1 Drilled top round.....109042-89
- 2 Adjustable Height column (shown).117466  
 Fixed Height column 27" (not shown).....  
 ..... 117468  
 Fixed height column 41" (not shown).....  
 ..... 117467
- 10 Drive screw RH#6 x 0.25.....000270
- 11 Nut, stop .50-13.....100678
- 12 Nut, locking M14 x 2.0 .....115212
- 13 1x2 Tube cap domed.....115476
- 14 Caster beam weldment.....117450B
- 15 Tube insert.....117479B
- 16 Caster body 3" locking..... 117481
- 17 Caster stem M14-2 x 0.88.....117482
- 20 Drive rivet .25 x .66..... 000213
- 21 Flat washer .34 x .69 x .06.....000299B
- 22 Spring washer .31.....000477Z
- 23 Spring pin .13 x 0.75.....100978B
- 24 Screw, hex .31-18 x 1.00.....104614B
- 25 Serial plate.....112822
- 26 Channel weldment.....117470B
- 27 Slide mount.....117475B
- 28 Instruction label.....117476
- 29 Spring compression.....117484
- 30 Spacer tube.....117489B
- 31 Pivot rod.....117490Z
- 32 Top plate weldment.....117491B
- 33 Washer .53x1.06x.09.....117454
- 34 Label, handle locator.....117477

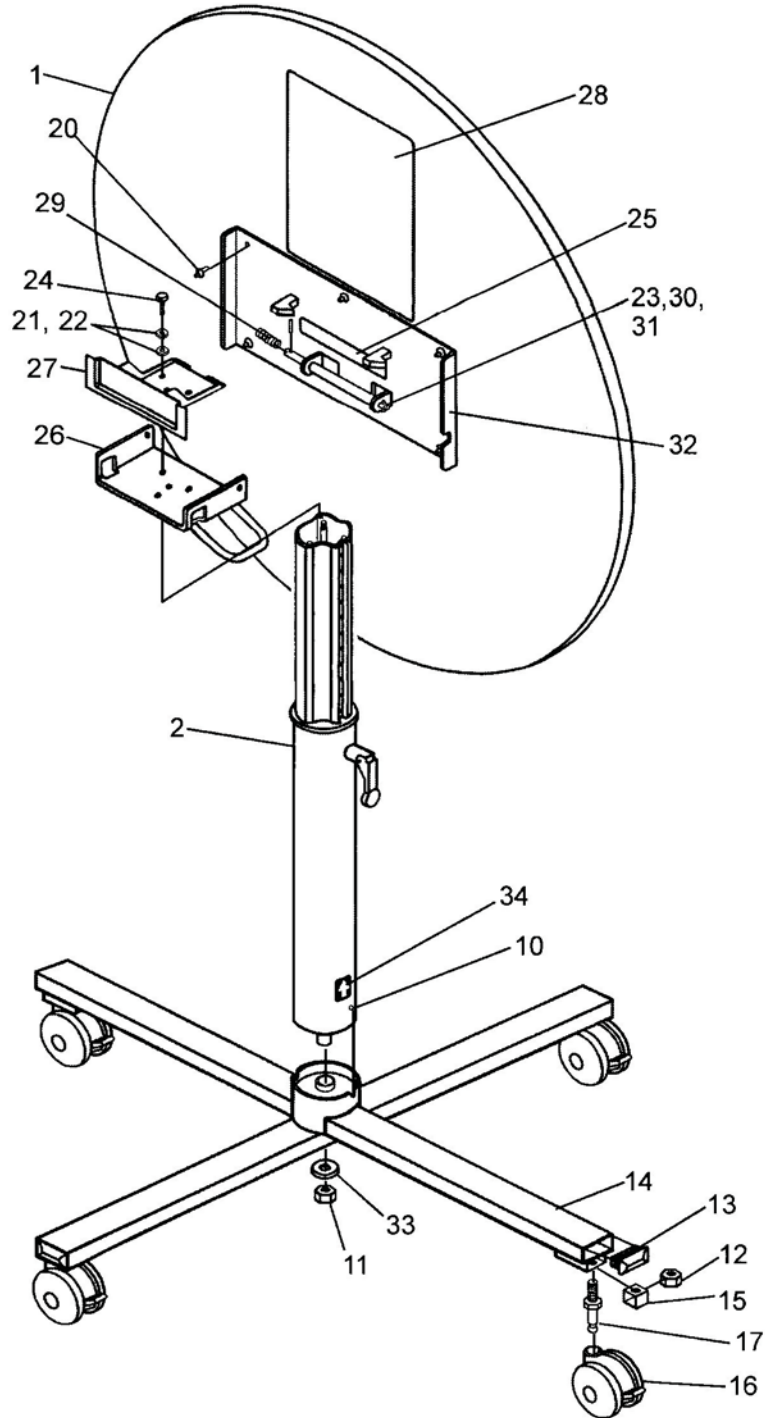

Sico reserves the right to substitute materials or make changes if materials are not available and/or such changes improve the product.